



# 4075 SafeClaw™ Concrete Anchor User Instructions

User Instructions for 3M™ 4075 SafeClaw Concrete Anchors.

Important: Keep these User Instructions for reference.

## General Safety Information

These *User Instructions* are not to be removed except by the user of this equipment. *User Instructions* must always be available to the user.



Compliant fall protection and emergency rescue systems help prevent serious injury during fall arrest. Users must read and understand the *User Instructions* provided with the product and be properly trained by their employer prior to use per OSHA 29 CFR 1910.66 and 1926.503 or applicable local standards. **Misuse or failure to follow warnings and instructions may result in serious personal injury or death.** For proper use, see supervisor, *User Instructions*, or call Technical Service at 800-243-4630.

### Purpose

3M 4075 SafeClaw™ Concrete Anchors are designed to be used as part of a personal fall arrest system, to help limit the fall arrest forces in the event of a fall.

### Use Instructions

1. Failure to follow all instructions and limitations on the use of the 4075 SafeClaw Anchor may result in serious personal injury or death.
2. Before using a personal fall arrest system, employees must be trained in accordance with the requirements of OSHA 29 CFR 1910.66 in the safe use of the system and its components.
3. Personal fall arrest systems, including the 4075 SafeClaw Anchor, must be inspected prior to each use for wear, damage, and other deterioration and defective components must be immediately removed from service, in accordance with the requirements of OSHA 29 CFR 1910.66 and 1926.502.
4. The complete fall protection system must be planned (including all components, calculating fall clearance, and swing fall) before using.
5. Users must have a rescue plan, and the means at hand to implement it, that provides the prompt rescue of employees in the event of a fall, or assures that employees are able to rescue themselves.
6. Store 4075 SafeClaw Anchors in a cool, dry, clean environment, out of direct sunlight, when not in use.
7. After a fall occurs, 4075 SafeClaw Anchors must be removed from service and destroyed immediately.

### Use Limitations

1. 4075 SafeClaw Anchors are designed for single users with a capacity up to 400 lb (181 kg) including clothing, tools, ect.
2. Do not use 4075 SafeClaw Anchors with horizontal lifelines systems.
3. 4075 SafeClaw Anchors must only be used in concrete with a minimum compressive strength of 3,000 psi (20.7MPa).
4. 4075 SafeClaw Anchors may be pulled in all directions up to 90°.
5. 4075 SafeClaw Anchors must be removed at the end of each day and not left inserted in hole overnight.
6. 4075 SafeClaw Anchors are designed to be used in temperatures ranging from -40°F to +130°F (-40°C to +54°C).
7. Do not expose 4075 SafeClaw Anchors to chemicals or harsh solutions which may have a harmful effect. Contact 3M Technical Service with any questions.
8. Caution must be taken when using 4075 SafeClaw Anchors near moving machinery, electrical hazards, sharp edges, or abrasive surfaces, as contact may cause equipment failure, personal injury, or death.
9. Minors, pregnant women and anyone with a history of either back or neck problems should not use this equipment.
10. Do not use/install equipment without proper training by a “competent person” as defined by OSHA 29 CFR 1926.32(f).
11. Only 3M, or persons or entities authorized in writing by 3M, shall make repairs or alterations to the equipment.

### Compatibility Limitations

All 3M 4075 SafeClaw Anchors must only be coupled to compatible connectors. OSHA 29 CFR 1926.502 prohibits snaphooks from being engaged to certain objects unless two requirements are met: snaphook must be a locking type and must be “designed for” making such a connection. “Designed for” means that the manufacturer of the snaphook specifically designed the snaphook to be used to connect to the equipment listed. The following connections must be avoided, because they can result in rollout\* when a nonlocking snaphook is used:

- Direct connection of a snaphook to horizontal lifeline.
- Two (or more) snaphooks connected to one D-ring.
- Two snaphooks connected to each other.
- A snaphook connected back on its integral lanyard.
- A snaphook connected to a webbing loop or webbing lanyard.
- Improper dimensions of the D-ring, rebar, or other connection point in relation to the snaphook dimensions that would allow the snaphook keeper to be depressed by a turning motion of the snaphook.

**\*Rollout:** A process by which a snaphook or carabiner unintentionally disengages from another connector or object to which it is coupled. (ANSI Z359.0-2007)

### Performance

3M 4075 SafeClaw Anchors have a minimum tensile breaking strength of 5,000 lbs (22.2 kN) when statically tested in accordance with the requirements of the ANSI Z359.1-2007 standard.

## Swing Falls

To minimize the possibility of a swing fall, work as directly under the anchorage connector as possible. Striking objects horizontally, due to the pendulum affect, may cause serious injury. Swing falls also increase the vertical fall distance of a worker compared to a fall directly below the anchorage connector.

## Installation

**⚠ Caution: Wear proper Personal Protective Equipment when drilling and blowing out hole. Safety glasses & gloves are recommended.**

Drill a 3/4 inch diameter hole 3 inches deep into concrete with a minimum compressive strength of 3,000 psi (20.7 MPa) utilizing a rotary hammer drill with industrial grade SDS bits.

**⚠ Warning: Do not drill anchor hole less then 6 inches from any corner or edge of concrete.**

Blow hole clean with compressed air. Bored hole walls must be straight and free of peaks and valleys on the inner wall surfaces. Place thumb inside the anchor loop and first two fingers around the trigger. Retract trigger until spring bottoms out. With other hand pinch the two spoons while holding trigger fully retracted. Insert the 4075 SafeClaw™ Anchor 3 inches deep into hole. Secure 4075 SafeClaw Anchor with a slight tug on the anchor loop. The stop sleeve must always be partially inserted into the hole. Connect fall arrest system to the anchor loop.

## Removal

Place thumb inside the anchor loop and first two fingers around the trigger and retract. If trigger does not retract and 4075 SafeClaw Anchor is stuck in hole, insert punch, screwdriver or pointed object into the hole until the tip rests on the bushing guide, see Fig. A. Bushing guide will be visible at the edge of the hole. Give a light, blunt tap with hammer or suitable object. Retract trigger and pull 4075 SafeClaw Anchor out of hole.

Fig. A

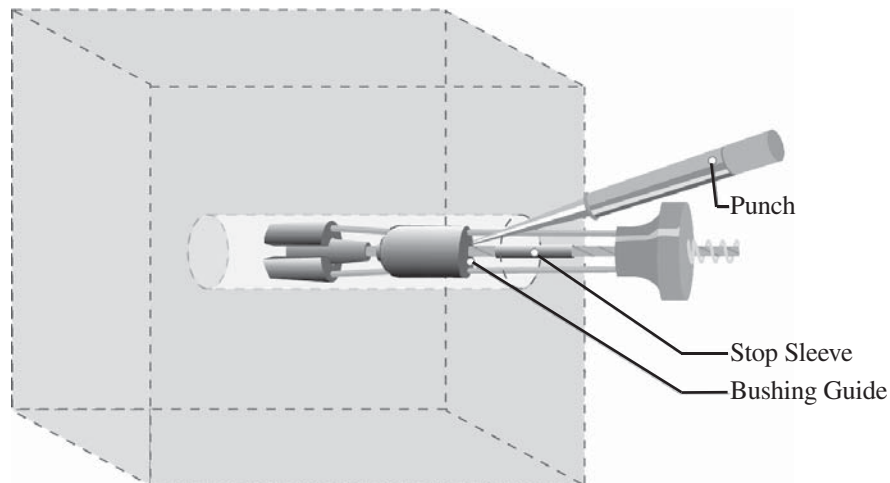

## Inspection

All 4075 SafeClaw Anchors must be inspected prior to each use, and annually by an OSHA defined “competent person” other than the user. Local, state, governmental and jurisdictional agencies may require the user to conduct more frequent or mandatory inspections.

**If inspection reveals any defect, inadequate maintenance, or unsafe condition, remove from service and destroy.**

All 4075 SafeClaw Anchors must be straight and the cable free of kinks or other damage. Bushing Guide must be able to slide along the cable.

**Any equipment that has been subjected to the forces of arresting a fall must be removed from service.**

All 4075 SafeClaw Anchors must be free of corrosion, chemical attack, alteration, excessive heating or wear.

All markings must be legible and attached to the product.

**Note: Only manufacturer, or entities authorized in writing by the manufacturer, may make repairs to the product.**

## Cleaning and Maintenance

4075 SafeClaw Anchors can be wiped down to remove grease, or dirt with a clean dry cloth. No maintenance is required for this product. If inspection reveals any defect, remove from service and destroy.

Part Number 3M ID	Material	Length	Connection	Capacity	Weight	Compliance Standards
4075 70071532330	Aluminum Alloy; Plated Steel; Stainless Steel; Air Craft Cable	11½ in (292 mm)	1½ in (38 mm)	400 lb (181 kg)	0.5 lb (227 g)	ANSI Z359.1-07

Inspection Date	Part Number	Serial Number	Comments	Inspector's Initials

Product Label

Inspect before each use. In addition, a competent person must inspect at least annually.		Not remove Label		US Patent 6,729,821 US Patent 7,011,281 US Patent 7,357,363
INSCRIPTION LOG Date Initial	<b>Compliance:</b> OSHA 29 CFR 1910.66 & 1926.502 ANSI Z359.1-2007 Max capacity 400 lbs.		<b>3M</b> <b>SafeClaw</b> 1-800-560-1094	<b>Model #</b> (Breaking strength rating) ( ) - 4075 (3/4" 5,000 lbs.) - Reference # 70071532330 ( ) - 4011 (3/4" 5,000 lbs.) - Reference # 70071605946 ( ) - 4077 (1" 10,000 lbs.) - Reference # 70071532348
	<b>Lot #</b> 0 1 2 3 4 5 6 7 8 9 0 1 2 3 4 5 6 7 8 9 0 1 2 3 4 5 6 7 8 9	<b>MFG. Date</b> M 1 2 3 4 5 6 7 8 9 10 11 12 Y 11 12 13 14 15		<b>WARNING: DO NOT use in wet or uncurd concrete.</b> Use in normal weight concrete with a compressive strength at least 3,000 PSI (20.7 MPa) Use for Fall Protection Only. * Do not use with incompatible connectors. * Avoid physical hazards such as thermal, electrical and chemical sources. * Avoid contact with sharp edges and abrasive surfaces.
			<b>Materials:</b> * Stainless steel * Aluminum alloy * Zinc plated copper * 7x19 aircraft cable	<b>Made in the USA</b>

**Product Warranty, Limited Remedy, and Limitation of Liability**

**WARRANTY:** THE FOLLOWING IS MADE IN LIEU OF ALL WARRANTIES OR CONDITIONS, EXPRESS OR IMPLIED, INCLUDING THE IMPLIED WARRANTIES OR CONDITIONS OF MERCHANTABILITY OR FITNESS FOR A PARTICULAR PURPOSE. Equipment offered by 3M is warranted against factory defects in workmanship and materials for a period of one year from date of installation or first use by the original owner.

**LIMITED REMEDY:** Upon notice in writing, 3M will repair or replace all defective items at 3M's sole discretion. 3M reserves the right to require that the defective item be returned to its plant for inspection before determining the appropriate course of action. Warranty does not cover equipment damage resulting from wear, abuse, damage in transit, failure to maintain the product or other damage beyond the control of 3M. 3M shall be the sole judge of product condition and warranty options. This warranty applies only to original purchaser and is the only warranty applicable to this product. Please contact 3M technical service department at 800-243-4630 for assistance.

**LIMITATION OF LIABILITY:** IN NO EVENT WILL 3M BE LIABLE FOR ANY INDIRECT, INCIDENTAL, SPECIAL OR CONSEQUENTIAL DAMAGES INCLUDING, BUT NOT LIMITED TO LOSS OF PROFITS, IN ANY WAY RELATED TO THE PRODUCTS REGARDLESS OF THE LEGAL THEORY ASSERTED.

**3M Occupational Health & Environmental Safety Division**

3M Center Building 235-2W-70  
 Saint Paul, MN 55144-1000  
 USA  
 Technical Assistance: 800-243-4630 in U.S.  
 800-267-4414 in Canada  
[www.3M.com/FallProtection](http://www.3M.com/FallProtection)  
[www.3M.com/PPESafety](http://www.3M.com/PPESafety)

Please recycle. Printed in USA.  
 © 3M 2012  
 3M and SafeClaw are trademarks of 3M Company, used under license in Canada.  
 All rights reserved.  
 IM-0049A (04-2012) 34-8709-9272-3